

**LIFAN POWER USA**



**ENGINES**

## **PREFACE**

Thank you for choosing the general gasoline engine produced by our company.

Based on the latest technology domestic and abroad, our Company, has individually developed general gasoline engine 2V77F with 4-stroke, V-shaped cylinder, forced-air cooling. The engine is characterized by advanced design, compact structure, reliable performance, convenient maintain, economic use, easy speed governing etc. It is widely used as ideal power in many fields such as generator, construction, field working, forestry machine, etc. The main hardware, such as crankcase, crankcase cover, cylinder all use aluminum alloy. Because of the using of automatic decompression mechanism and centrifugal flyweight speed governor, the starting is very convenient and reliable. Other type use level sensitive protection system, avoiding the suddenly damage caused by bad lubrication.

The manual gives information about the operation and maintenance of gasoline engine 2V77F and 2V77F-A. 2V77F is started by electricity while 2V77F-A is started by electricity or manual. Please read it carefully before operating. To extend the service life, users should strictly follow the stipulations stated in the manual to carry out operating and maintenance. We have maintaining place on local place, it will supply offer you the service.

This manual should be considered a permanent part of the engine and should remain with it if it is resold.

All the materials and diagrams of this manual are in accordance with the newest products at the publishing time. Due to revision and other change, the information described in this manual may be a little different from the actual status. The manual is subject to change without notice.

The copyright of this manual belongs to our Co, any group or individual is forbidden to reprint or copy any it.

## IMPORTANT NOTICES

Please pay special attention to statements preceded by the following words:

### WARNING

● A warning is used to alert the user to fact that hazardous operation and maintenance procedures may result in injury to or death of personnel if not strictly observed.

### CAUTION

● A caution is used to alert the user to fact that hazardous operation and maintenance procedures may result in injury to personnel or destruction of equipment if not strictly observed.

### NOTE

● Give helpful information.

This manual should be considered as a permanent part of the unit and should remain with the unit when resold.

# CONTENTS

<b>SAFETY PRECAUTIONS</b> .....	6
<b>PARTS DESCRIPTION</b> .....	7
<b>BATTERY CONNECTION(electric-start type)</b> .....	8
<b>CONTROL CONNECTION OF REMOTE DISTANCE (OPTION)</b> .....	10
<b>PRE-OPERATE INSPECTION</b> .....	12
I . Engine oil .....	12
II .Air cleaner.....	13
III . Fuel and fuel tank.....	14
<b>STARTING THE ENGINE</b> .....	15
<b>RUNNING THE ENGINE</b> .....	17
I . Engine oil alarm .....	17
II .Breaker .....	18
<b>STOP</b> .....	19
<b>EXHAUST CONTROL SYSTEM</b> .....	20
<b>MAINTENANCE</b> .....	22
I . Maintenance schedule .....	22
II . Maintenance method .....	23
<b>TRANSPORT, STORAGE AND REMOVAL FROM STORAGE</b> .....	32
<b>TROUBLESHOOTING</b> .....	34

I . Start engine difficultly.....	34
II . Low gasoline engine power output .....	36
III. Gasoline engine cannot run smoothly .....	37
IV . Stop suddenly when running .....	38
V . Gasoline engine is excessively hot.....	39
VI. There exists abnormal noise when engine running .....	40
<b>SPECIFICATIONS</b> .....	41
I . Main specification .....	41
II . Torque of important bolts.....	42
III. Fitting clearance and wear limit .....	43
<b>ELECTRIC DIAGRAM</b> .....	44

## **SAFETY PRECAUTIONS**

### **WARNING:**

**Before operating the engine, be sure to read and familiar with the manual carefully, otherwise personal injury or equipment damage may occur.**

Please pay special attention to the following:

1. Running the engine in a well-ventilated place, keep it at least one meter away from building walls or other equipments, keep away from inflammables such as gasoline, matches and so on to avoid possibility of fire.
2. This engine should not be used underground.
3. This engine should not be used in areas where explosive conditions are present.
4. Keep the engine out of reach of children and pets to avoid accidents.
5. Operator of the engine has been specially trained.
6. Refuel in a well-ventilated area with the engine stopped, and in places refueling or storing gasoline, no smoking and any flames or sparks.
7. Refuel the fuel tank not too full so as to avoid fuel's spilling out. If there is spilled fuel around, be sure to clean it thoroughly before starting.
8. Locate the engine on a level-working platform to avoid fuel's spilling out.
9. Make sure the fuel filler cap is tightened securely.
10. The exhaust muffler is very hot during running the engine even after the engine stops. Never touch it, or you may get burns. Transport or store the engine with it cooling down entirely.
11. This machine should not be used underground or in areas where explosive conditions may be present.
12. It's recommended that the operator wears the ear protection equipment during operation.

## PARTS DESCRIPTION

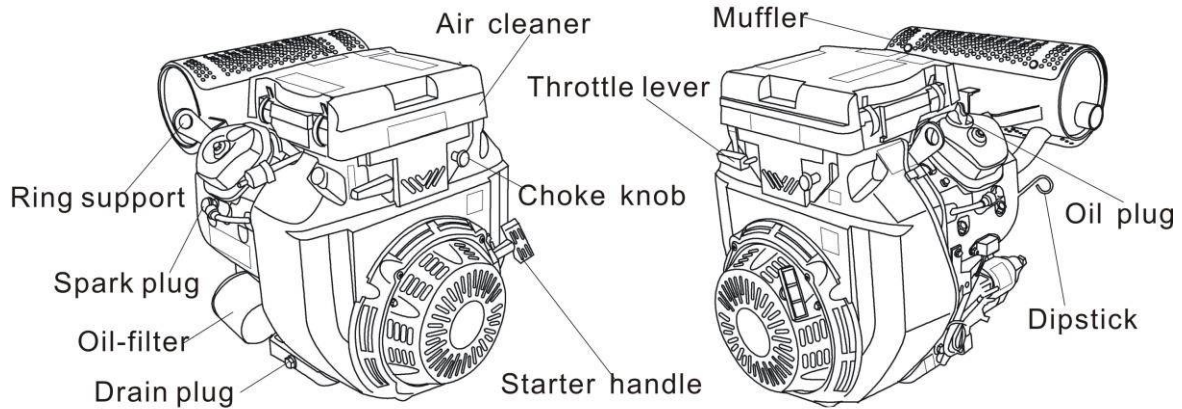


Fig. 1

## BATTERY CONNECTION(electric-start type)

In the case that the specifications of the battery are 12V and more than 45A.h, connect its positive lead to the electromagnetic coil while connect its negative lead to engine mount strew, base screw or any place capable of grounding with the engine well.

Make sure the battery leads are connected tightly and no corrosion. If any, eliminate it.

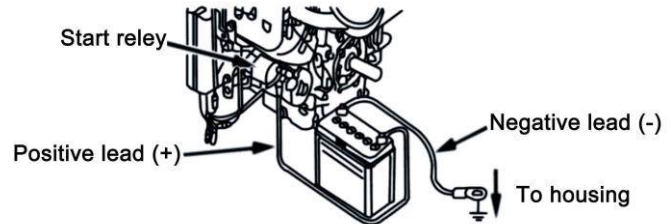


Fig. 2

### **WARNING:**

- The battery may give off explosive gas, keep sparks, flames and cigarettes away. Charge or use it in an area with good ventilation.
- The battery contains sulfuric acid (electrolyte). Contact with skin or eyes may cause severe burns. Wear protective clothing and a face shield. If electrolyte gets in your skin, flush with water; if gets in your eyes, flush with water for at least 15 minutes and call a physician at once.
- Electrolyte is poisonous. If swallowed, drink large quantities of water or milk, and follow with milk of magnesia or vegetable oil and call a physician.
- Keep out of reach of children.



## **CAUTION:**

- **Do not add tap water to the battery instead of distilled water, or the battery life will be shortened.**
- **Do not add distilled water over electrolyte upper level mark, or electrolyte will spill out to corrupt the engine parts. If so, be sure to wash them away with water.**
- **Make sure not to connect the battery leads in reverse order, or short-circuit or breaker's cutting may occur.**

## CONTROL CONNECTION OF REMOTE DISTANCE (OPTION)

Throttle and choke levers are designed with holes for optional cable accessories.

1. The diagram shows the installation method of single strand cable and woven cable.

a) Remote-controlled choke valve and Remote-controlled throttle valve.

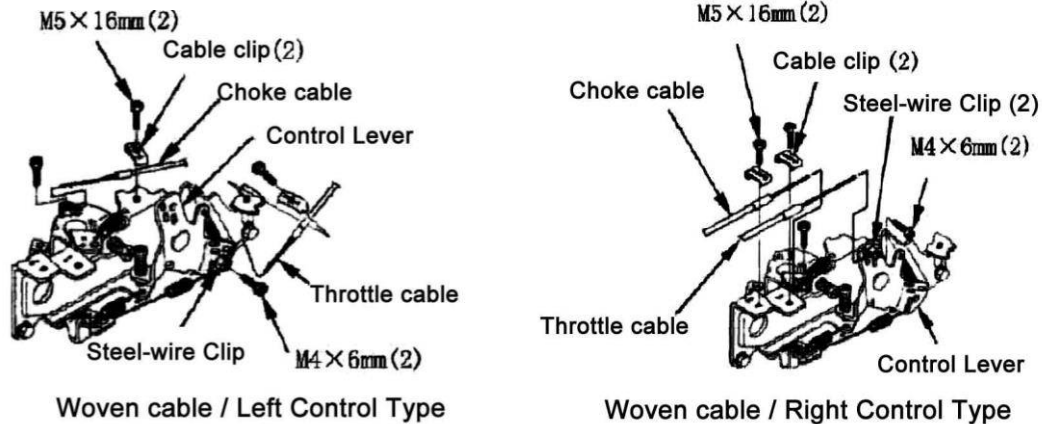


Fig.3

b) Remotely –controlled throttle valve and Manually-controlled choke valve

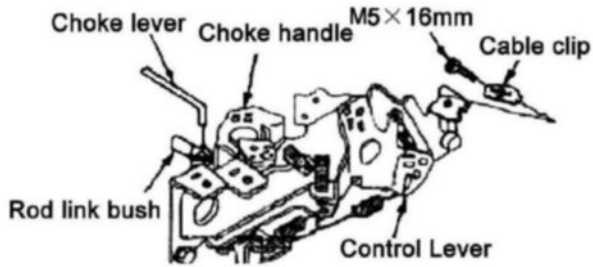


Fig. 4

c) Manually-controlled throttle valve and Manually-controlled choke valve

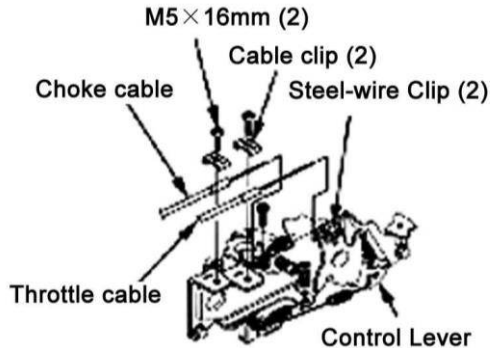


Fig. 5

Single strand cable / Right Control Type

2. Put the levers of both the choke and throttle on the controlled pedestal.

# PRE-OPERATE INSPECTION

## I . Engine oil

### CAUTION:

● Engine oil is a key factor in deciding the engine's performance. Do not use engine oil with additives or 2-stroke gasoline engine oil, as they haven't enough lubrication, which may shorten the engines service life.

● **Check the engine when it on a level ground.**

Recommended engine oil: SAE10W-30

As viscosity varies with regions and temperatures, so the lubricant has to be selected in accordance with our recommendation.

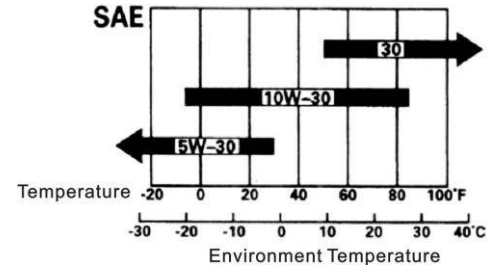


Fig. 6

### CAUTION:

**Use cleanser-free oil or two-stroke engine oil will shorten the machine's life.**

Check steps:

- 1) Ensure that the engine is stops on a level ground.
- 2) Remove the dipstick (Fig.7) and clean it.
- 3) Reinsert the dipstick into the oil filler without screwing it, and check oil height.

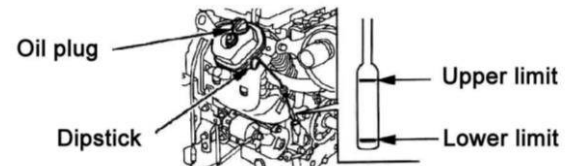


Fig. 7

- 4) if the oil level is too low, fill the recommended oil to the upper level mark.
- 5) Reinstall oil plug and dipstick.

### CAUTION:

1. Run with insufficient engine oil may severe damage the engine.
2. Please stop the engine and check it on ground level.

### II .Air cleaner

Dismantle the air cleaner cover (Fig. 8), and check its filter element, make sure it clean and intact. Otherwise clean or replace it.

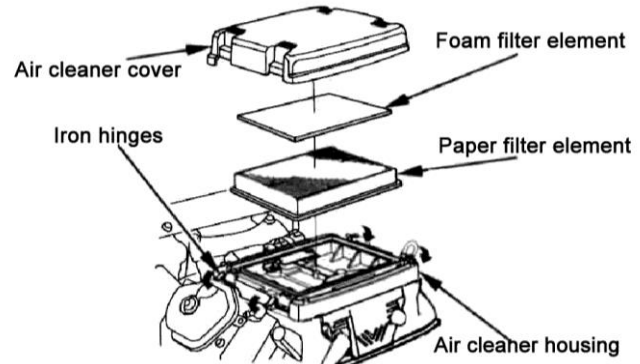


Fig.8

## **CAUTION:**

- 1. Do not allow the engine in operation without air cleaner, or it will speedup its abrasion.**
- 2. Keep dust and fragment out of the air cleaner housing.**

### **III. Fuel and fuel tank**

The engine must apply unleaded gasoline with an octane number over 86.

Using unleaded gasoline will decrease the possibility of producing carbon deposit and will prolong the engine's service life.

Never apply used or polluted gasoline or a mixture of gasoline with engine oil. Make sure the fuel is free of dirt and water

## STARTING THE ENGINE

### CAUTION:

PPE devices (ear protection, gloves) should be used before start the engine.

1. Push the fuel cock to “ON”. (Fig.9) (Option)

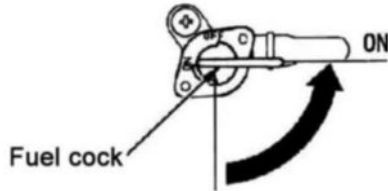


Fig. 9

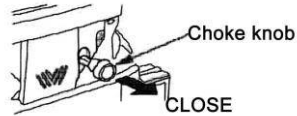


Fig.10



Throttle lever

Fig.11

2. Push the choke lever to “CLOSE”. (Fig.10)。
3. Push the throttle to “FAST” slowly.
4. Start the engine as follows:
  - a). Hand-operated kick-starter

Pull slightly the starting rope handle up until feeling anti-action, and then make a rapid pull.

### CAUTION:

Releasing the handle suddenly may make it hitting the engine. Release the handle slowly conforming with its recoiling force.

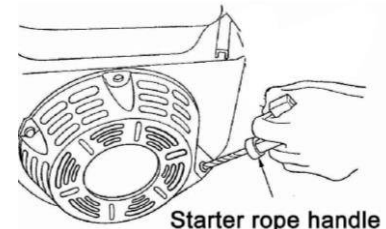


Fig.12

b) Electric starter

Push the engine switch to “START” and keep 5 seconds to make it start.

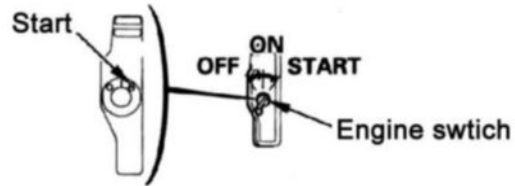


Fig.13

**CAUTION:**

Use the engine switch not than 5 minutes each time to avoid damage of the engine. Try again 10 seconds later after last attempt failures. Once engine starts, push the engine switch to “ON”.



## RUNNING THE ENGINE

1. If the engine starts when the choke knob “CLOSE”, please push it to “ON” immediately after the engine runs smoothly.

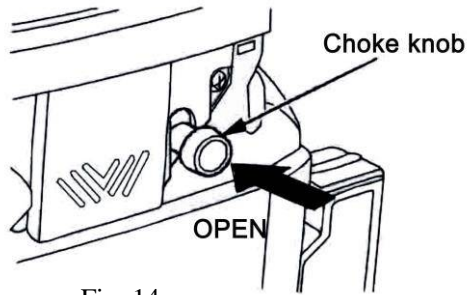


Fig. 14



Fig. 15

2. Set the throttle lever in proper position to ensure the engine runs at required velocity.

### 1 . Engine oil alarm

The engine oil alarm is designed to function when the engine oil in the crankcase is insufficient. Lack of engine oil may damage the engine. Once oil level in the crankcase is too low, the engine oil alarm will stop the engine automatically to make it free of damage while the engine switch is still at “ON ”.

## **CAUTION:**

**If cannot restart the engine, check the engine oil level first before go to other check items.**

## **II .Breaker**

The breaker which protect the charging circuit of the battery will cut off automatically in the case that short circuit or incorrect connection of the battery poles occurs.

The green indicator in the breaker will jump out with the circuit cutting off. After finding troubles and troubleshooting, depress the breaker button to turn the breaker on.

## **III . Operating on highlands**

On highlands, the standard mixture ratio is relatively too big so the engine performance may be impaired while the fuel consumption may increase, besides, too big mixture ratio will pollute the spark plug and result in starting the engine difficultly. This problem can be solved by amending the carburetor technological status. If always using on highlands with at 1800 meters above sea level, ask your dealer for help.

However, the engine power will decrease by about 3.5% with every 305 meters up in height.

## **CAUTION:**

Amended engine applicable to highlands may be damaged seriously in area below altitude of 1800 meters for overheating, because its mixture ratio is too small for operation in low altitude area. In the case, ask your dealer to recover the engine to its normal technical status.

## STOP

In an emergency, push the engine switch to “OFF” to stall the engine. Normally, stop it in the following steps:

1. Push the throttle lever to (SLOW) slowly. (Fig. 16)
2. Push the engine switch to “ OFF ”. (Fig.17) 。
3. Set the fuel cock to “ OFF ”. (Fig.18) 。（Option）

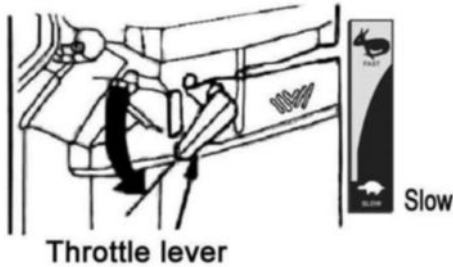


Fig. 16

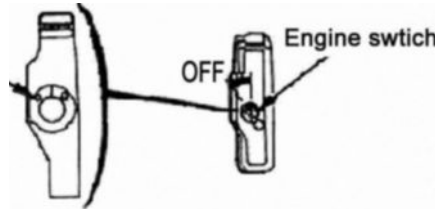


图 17

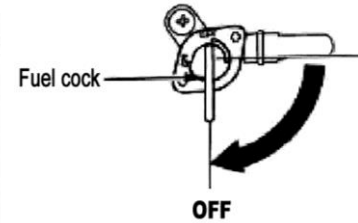


Fig. 18

### CAUTION:

Never sudden stopping at high speed with heavy load is, otherwise it will damage the engine.

## **EXHAUST CONTROL SYSTEM**

When the engine running, carbon monoxide, oxide of nitrogen and hydrocarbon will produce, and in certain conditions, oxide of nitrogen and hydrocarbon will react chemically each other to make smoke while carbon monoxide is toxic, so exhaust control of them is very important. The company decreases the exhaust emissions by introducing poor-fuel carburetors and other devices into the engine to solve the problem.

To meet the exhaust with in the standard exhaust emission, pay attention to the following:

### **1.Maintenance**

Maintain the engine periodically in accordance with the maintenance schedule in the manual. The maintenance schedule is made out on the base of normal use in normal conditions, if using under heavy load, dusty or wet circumstances or in high temperature, service of the engine should be done more often.

### **2.Replacement of parts**

We recommend that you should choose the parts which are manufactured by our company or equivalent to these in quality as replacement ones. Replacement without so high quality as the original may impair the exhaust control system in effectiveness.

### **3.Modifying**

Modifying the exhaust control system may make actual exhaust emissions exceeding statutory limit values. Illegal modification as such:

- 1) Dismantle or modify any part of air intake or exhaust system.
- 2) Modify or take off speed – adjusting connection device or speed adjustment device to result in the engines running beyond the set parameters.

#### **4.Problems affecting exhaust emissions**

- 1) Starting or stopping difficult.
- 2) Unstable idling.
- 3) Give off back smoke or consume too much fuel.
- 4) Under the condition of load, poor ignition sparks or sparks returned
- 5) Ignite too early.

Once you find any of above problem, contact your dealer for help.

# MAINTENANCE

## I . Maintenance schedule

In order to keep the engine under the good condition, you must take maintain and adjust for it periodically. Please use following schedule to maintain and check.

Frequency		Each time	First month or 20 hrs	Each season or 50 hrs	Every 6 month or 100 hrs	Each year or 300 hrs
Item						
Engine oil	Oil level check	√				
	Replace		√		√	
Air cleaner	Check	√				
	Clean			√①		
	Replace					√
Spark plug	Clean, adjust				√	
	Replace					√
Spark eliminator	Clean				√	
Idling	Check-adjust					√②
Valve clearance	Check-adjust					√②
Oil-filter	Replace					√②或 200 hrs
fuel filter	Clean					√②
Fuel supply line	Check	Every two years (do a replacement if necessary)				

## **CAUTION:**

- 1. Please stop the engine before serving.**
- 2. In order to prevent engine from the suddenly start, please turn off the ignite switch and put down the spark plug cap.**

## **CAUTION:**

**Use only parts from the company or equivalents in quality; otherwise engine damage may result.**

- ① More often than that in the schedule if in dusty circumstances.**
- ② Should be done by your dealer unless you are specially trained and is well equipped with tools.**

## **II. Maintenance method**

- 1. Replacement of engine oil (checking method, please refer to P 11 )**

Let the oil to flow out of gasoline engine when it under the hot condition, and make sure that the flow is fast and complete.

- 1) Turn off the oil filler cap (Fig.19) and drain plug (Fig.20) to drain engine oil thoroughly. Reinstall the drain plug and screw securely.**
- 2) Fill the specified engine oil up to the upper level mark.**
- 3) Reinstall the oil filler cap.**

Engine oil capacity in the reduction gearbox is 0.3 liters, engine oil capacity in the crankcase is 1.1 liters.

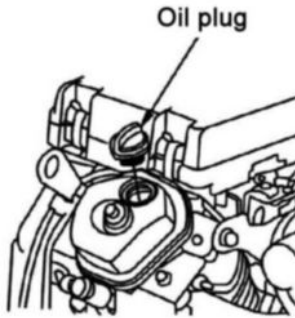


Fig. 19

Engine oil capacity in the crankcase is 1.4 liters.

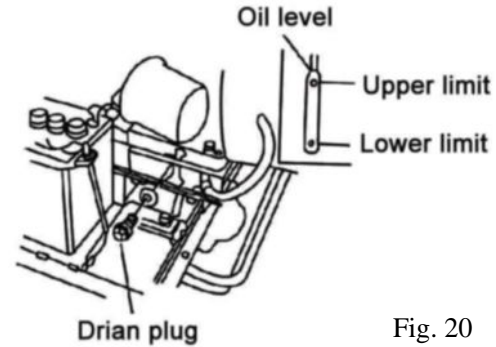


Fig. 20

## **NOTE:**

**Do not throw oil containers or discarded engine oil into rubbish boxes or onto the ground. For the sake of environmental protection, we suggest you throw the discarded engine oil into a closed container and bring to local recycling station.**

## **2. Replacement of oil-filter**

- 1) Exhaust engine oil.
- 2) Use the spanner to disassembly the oil-filter to exhaust the remained oil.
- 3) Clean the oil-filter housing.



- 4) To put a layer of clean engine oil on the “O” shaped seal ring, then fix it on the seat of oil-filter.
- 5) Daub a lay of clean oil on the surface of “O” ring and install it on air cleaner housing.
- 6) Oil-filter should be fixed by the tensional spanner which followed by specified angle or torque.

Torsional angle:  $7/4r$

Torque:  $22N\cdot m$

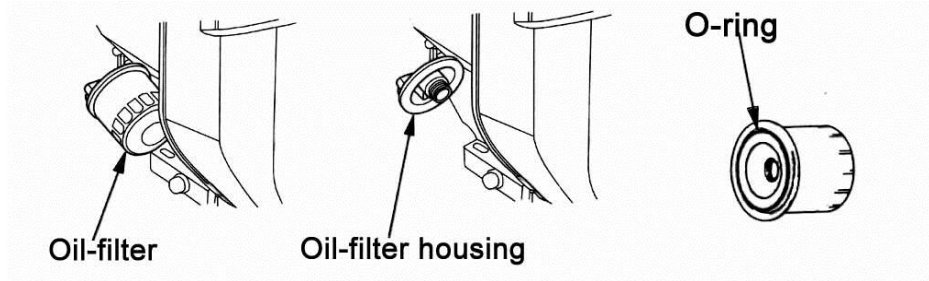


Fig. 21

### 3. Maintenance of air cleaner

A dirty air cleaner will limit the air into the carburetor. To keep the carburetor in good working conditions, please Maintenance the air cleaner periodically. If operating the engine in extremely dusty area, the job should be done more often.

## **WARNING:**

Never clean the foam and paper filter element with in gasoline or low flash-point detergents, or explosion may happen.

## **CAUTION:**

Never run the engine without an air cleaner, or dirt and dust may enter the engine so speed the engine's wear.

- 1) Loosen the four iron hinges, dismantle the air cleaner cover (Fig.22), and check carefully if the two filter element are damaged, if the are, please change a new.
- 2) If you want to use them again, please clean the filter element.

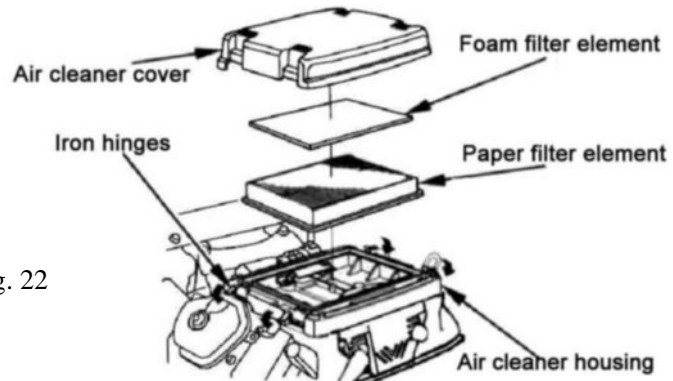


Fig. 22

Foam filter element:

clean it with home detergents and warm water (or non-flammable or high flash-point cleansing solvents) and dry up, then soak in clean engine oil until saturated. Squeeze out excess oil, otherwise, the engine will discharge smoke in starting stage.

Paper filter element:

knock it on a solid ground to get rid of accumulated dust or blow out dust from inside to outside with high-pressure air flow (not more than 30 psi). Never clean with a brush, as brushing may force the dust into the core fiber. If the core is extremely filthy, replace with a new one.

- 3) Clean the dust in the air cleaner cover avoid it enter the air-intake of the carburetor.
- 4) Reinstall the filter element and air cleaner housing and fix the iron hinges.

#### **4. The maintenance of spark plug**

Spark plug type: BPR6ES (NGK) or NHSP LD F7RTC

### **CAUTION:**

**Never use the spark plug with unusual heat range.**

Proper spark plug clearance ensures the engine's normal running under no deposit around the spark plug.

- 1) Remove the spark plug cap, Dismantle the spark plug with a spark plug wrench. (Fig. 23) 。

## WARNING:

If the engine operates all the time, muffler will be very hot, so please don't touch the muffler.

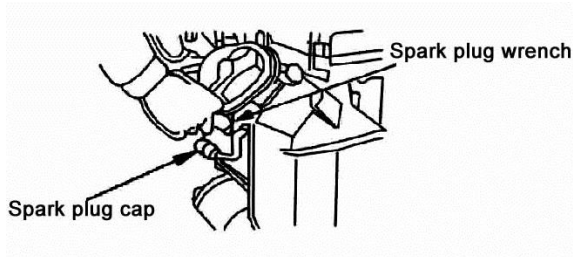


Fig. 23

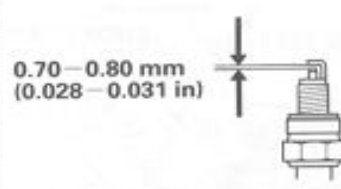


Fig. 24

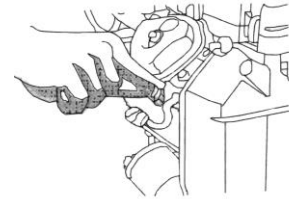


Fig. 25

- 2) Check spark plug carefully, if there is distinct corrosion, or crack or cast in the insulator, this spark plug should be rejected. If this spark plug will be used again, use steel brush to clean it.
- 3) Measure the spark plug clearance with a feeler, The clearance should be 0.7~0.8mm. If adjustment is necessary, bend the side electrode carefully. (Fig.24) .
- 4) Please check if the spark plug mat is in good condition, screw it by hand.
- 5) When the spark plug is in place, revolve it by spark plug wrench, and impact gasket (Fig. 25) .

**CAUTION:**

If a new spark plug is used, twist 1/2 more turns after impacting the gasket,  
If reinstall the original one, just twist 1/8-1/4 more turns.

**CAUTION:**

The spark plug must be tightened securely, or it may become very hot to damage the engine.

Use the recommended spark plug or the equivalent. Incorrect heat range of the spark plug may damage the engine.

**5. Spark eliminator (option)**

The spark eliminator should be serviced at least once every 100 hour's operation so as to keep it in a sound condition.

**WARNING:**

The muffler is very hot during running the engine and even a long time after stopping. Never touch it, or you may get burned. Service after the engine cools down.

- 1) Screw off the special screw from muffler and remove the spark suppressor.
- 2) Clear away carbon deposit from the spark eliminator mesh with a brush.

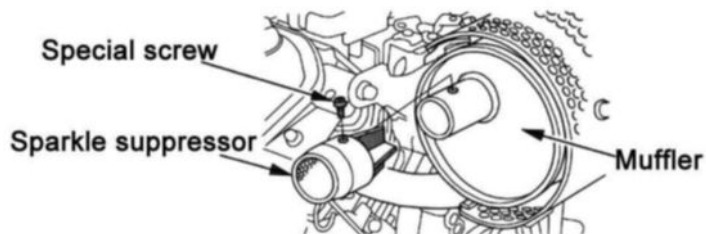


Fig.26

### **CAUTION:**

**Be careful and do not damage of the spark eliminator mesh.**

### **NOTE:**

**Sparkle eliminator can never be damaged, otherwise please use a new one.**

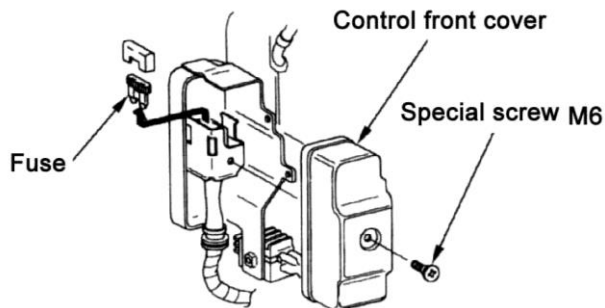
- 3) Install spark eliminator and muffler in term of the order of disassembly.

## 6. Change the fuse

When the fuse is fusing, it means the turnoff of circuitry or over loading. Please contact with the dealer about repair.

Rated current: 25A

1. Screw off M6 special bolt from the cover of switch box and remove the cover.(Fig.27)
2. Pull out broken fuse from pedestal by hand and the insert new fuse.



### NOTE:

Fig. 27

**Don't use the fuse different form rate specification. Or it will make the circuitry seriously mangled or cause a fire.**

Before checking or changing a fuse, sever ignition switch and pull out the key in order to prevent short circuit.

## TRANSPORT, STORAGE AND REMOVAL FROM STORAGE

### Transport

Transport with the fuel cock turned off. Transport or store the engine when it is cool so as to avoid getting burns or fire.

### CAUTION:

Do not incline the engine so as to avoid fuel's spill. Spilled fuel or fuel vapor may ignite to cause fire.

### Storage

If the engine is not use for a long time, be sure to store it properly.

1. Make sure the storage area is dry and free of dust.
2. When using it again, please maintain it as following.

STORAGE TIME	In order to avoid hard starting, maintain procedure suggestion
Within one month	Non
One ~ two months	Drain out original fuel of the fuel tank and refuel
Two month ~one year	Drain out original fuel of the fuel tank and refuel; Drain out fuel in the carburetor①; Empty the deposit cup②
Above one year	Drain out original fuel of the fuel tank and refuel; Drain out fuel in the carburetor①; Empty the deposit cup② Move the engine from the storage place, fill it with fuel, then start up it.
① Screw off the drain plug(Fig.28) and drain out fuel in the carburetor. Please drain the fuel to profitable container, screw down the drain bolt.	
② Turn off the engine switch first, disconnect the deposit cup and empty it, Reinstall the deposit cup and screw down.	



## **WARNING:**

**Fuel is extremely flammable and explosive under certain conditions. Keep cigarette, open flames and sparks away from operating site.**

3. Replace engine oil.

4. Disconnect the spark plug. Fill about a spoon of fresh engine oil from the spark plug mount hole onto the cylinder. Crank the engine up to distribute engine oil evenly. Reinstall the spark plug.

5. Electric start type: disconnect the battery and store in dry and cool area.  
Charge one time every month.

6. Cover the engine to keep dust away.

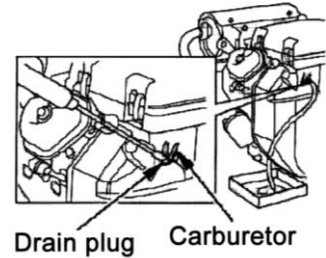


Fig.28

## TROUBLESHOOTING

### I . Start engine difficultly

ITEM	CAUSE	REMEDY
Check battery connection	Incorrect connection	connect in proper way (P.5)
Check battery	No charge or under charge, corrosion	Check the breaker, charge the battery or replace it

Check the machine according the following table if the motor runs well

TROUBLE			CAUSE		REMEDY
Normal compression of cylinder	good spark plug	Abnormal fuel supply system	Oil flow is not smooth or no oil flow	There is no enough fuel in fuel tank or fuel cock is closed.	Fill fuel, open fuel cock.
				Air vent in the fuel filler cap is clogged.	Dredge air vent.
				Fuel cock is clogged.	Clean first and then dredge.
				Improper or clogged main oil flow hole.	Readjust or clean, blow to get through.
				Needle valve is not closed properly or start hole is clogged.	Dismantle needle valve and repair, clean, blow to get through.
				Float is damaged or sticking.	Repair float.
			Oil flow smoothly	Fuel is too filthy or deteriorated.	Replace.
				There is water in fuel.	Replace.
				Too much fuel in engine.	Drain extra fuel, dry up spark plug electrodes.
				Wrong fuel brand.	Select proper fuel brand corresponding with the requirements.

TROUBLE			CAUSE		REMEDY
Normal compression of cylinder	normal fuel supply system	good high pressure wire	bad spark plug	Too much carbon deposit and dirt around electrodes.	Clear away.
				Electrodes are burn damaged seriously or insulators damaged.	Replace spark plug.
				Improper electrodes gap.	Adjust to proper value.
		high pressure wire is not workable	good spark plug	High – pressure coil is damaged.	Replace
				Ignition coil is damaged.	Replace
				Magneto loses magnetism.	Replace
Abnormal compression of cylinder	normal fuel supply system	Normal ignition system		Piston ring is worn to or even over its wear limit.	Replace
				Piston ring is broken.	Replace
				Piston ring is sticking.	Clear up carbon fouling.
				Spark plug is not installed tighten or without a gasket.	Tighten with a gasket in.
				Air leakage between cylinder block and cylinder head.	Check cylinder gasket, and the flatness of the surface by which cylinder block contacting with cylinder head, tighten cylinder head bolts in stipulated order to stipulated torque.
				Air leakage in valves.	Check valve. Clearance and tightness, repair if necessary.

Ask your dealer for help if you still can not start the engine.

**WARNING:**

- When testing the spark plug, never hold the high- voltage wire of the spark plug with wet hand.
- Make sure there is no spilled fuel outside the engine and that the spark plug isn't dipped with fuel.
- To prevent fire, keep sparks far away from the spark plug mount hole.

**II. Low gasoline engine power output**

<b>TROUBLE</b>	<b>CAUSE</b>		<b>REMEDY</b>
When turning throttle greater, speed increase responds slowly or speed is decreased even engine stops running.	Ignition system	Incorrect ignition time.	Readjust ignition advance angle
	Fuel supply system	Air in fuel line or fuel line clogged.	Exhaust air or dredge fuel line
		Main oil flow hole is not adjusted properly.	Readjust
		In carburetor, needle valve hole and main oil flow hole clogged.	Clean and blow to get through
		Fuel cock is clogged up.	Clean, replace damaged part
		Too much carbon deposit in combusting chamber.	Clear away
		Too much carbon fouling in muffler and exhaust pipe.	Clear away
		Air cleaner is clogged up.	Clean air cleaner filter elemei
		Intake pipe is leaking.	Repair or replace
	Poor compression	Piston or cylinder or piston ring is worn.	Replace the worn
		Air leakage from the surface by which cylinder block contacting with cylinder head.	Replace cylinder gasket
		Too big or too small valve clearance.	Readjust
		Valve tightness is poor.	Repair

### III. Gasoline engine cannot run smoothly

<b>TROUBLE</b>	<b>CAUSE</b>	<b>REMEDY</b>
Engine is pinking	Piston, cylinder or piston ring is worn excessively.	Replace the worn
	Piston pin and piston pin hole are worn excessively.	Replace piston or piston pin
	Tie rod small head is worn excessively.	Replace tie rod
	Roller bearing for crankshaft main shaft is worn.	Replace roller bearing
Abnormal combustion	Engine is too hot	Shoot trouble
	Too much carbon deposit in combustion chamber	Clear away
	Improper gasoline brand or low gasoline quality	Replace with qualified gasoline
Engine cannot start because of spark lacking	There is water in float chamber	Clean
	Improper spark plug electrodes clearance	Adjust
	Incorrect ignition time	Readjust
	Something wrong with induced coil, and so on	Check and replace damaged parts

#### IV. Stop suddenly when running

TROUBLE	CAUSE		REMEDY
Stop suddenly when running.	Fuel supply system	Fuel is used up	Refill fuel
		Carburetor is clogged	Check fuel line and dredge
		Float is leaking	Repair
		Needle valve sticks	Dismantle float chamber and eliminate it
	Ignition system	Spark plug is struck through, or short-circuited by carbon deposit	Replace spark plug
		Side electrode of spark plug is dropped out	Replace spark plug
		High-pressure wire is dropped out	Weld on
		Ignition coil is struck through to be short-circuited	Replace ignition coil
		Parking wire is located on engine body	Find out meeting and insulate
The other	Cylinder is pulled damage, valve is dropped out	Repair or replace damaged parts	

### V. Gasoline engine is excessively hot

TROUBLE	CAUSE	REMEDY
Gasoline engine is excessively hot	Improper ignition time	Adjust ignition advance angle properly
	Insufficient fuel supply	Refill engine oil
	Exhaust pipe is blocked up	Dredge exhaust pipe
	Flow guard is leaking	Repair damaged part
	Dirt or something like this fill up among air cooling fins	Clear away dirt or something like this
	Cooling fan is loosen, losing function	Reinstall well
	Tie rod deformation makes piston and cylinder bushing side wear	Replace tie rod
	Cylinder or piston or piston ring is worn, resulting in air flow between cylinder and crankcase	Replace the worn
	Improper adjustment of engine speed produces excessive rotational speed	Readjust engine speed to proper valve by speed regulator
	Crankshaft main bearing is burnt out	Replace main bearing

**NOTE:** the gasoline should run under cretin temperature. Generally, permitting temperature at the flow guard outlet is between 80- 110°C, while the temperature of the crankcase is about 60°C under the magneto. If temperatures surpass the limits, it is an indication that the gasoline engine is excessive hot.

**VI. There exists abnormal noise when engine running**

<b>TROUBLE</b>	<b>CAUSE</b>	<b>REMEDY</b>
There is noise of beating	Piston, piston ring or cylinder is worn	Replace the worn
	Tie rod or piston pin and piston pin hole is worn	Replace the worn
	Crankshaft main bearing is worn	Replace
	Piston ring is broken	Replace
There is metal-beaten noise in abnormal combustion	Too much carbon deposit in combusting chamber	Clear away carbon deposit
	Too small electrode clearance of spark plug	Adjust electrode clearance properly
	Engine is flooded with fuel	Check relative parts such as carburetor
	Improper fuel brand	Replace fuel
	Engine is excessively hot	Find a cause and eliminate it
The other	Improper valve clearance	Readjust valve clearance properly
	Fly wheel is not connected with crankshaft tightly	Connect tightly



## SPECIFICATIONS

### I . Main specification

Model Items	2V77F	2V77F-A	2V78F
Engine type	V-shaped, double-cylinder, 4- stroke, forced air-cooled, OHV		
Bore × Stroke (mm)	77mm×66mm		78mm×67mm
Displacement	614ml		640ml
Compression Ratio	8.3 : 1		8.5 : 1
Max power output	12.5kW(17PS)/3600rpm		13kW(17PS)/3600rpm
Recommend power using	12kW(16.3PS)/3600rpm		12.5kW(16.3PS)/3600rpm
Max torque	40N • m /2,500rpm		42N • m /2,500rpm
Ignition system	Non-compact transistorized ignition (TCI)		
Start Model	Electric	Electric /Manual	Electric
Air cleaner	Semi-dry or oil bath type		
Lubricating model	Pressure + sputtering		
Fuel consumption	≤370g/kw.h		
Oil capacity	1.4L		
Dimensions (L×W×H)	455mm×400mm×450 mm	455mm×460 mm×450 mm	455mm×400mm×450 mm
Bo×Dimensions (L×W×H)	500mm×430 mm×550 mm		
N. W	42Kg	44Kg	46Kg

## DATA RELATING ADJUSTMENT

Item	Data
Spark plug clearance	0.7~0.8mm
<b>Carburetor</b> Idling	1500±150rpm
Valve clearance (cold engine)	<b>Intake:</b> 0.15±0.02 <b>Exhaust:</b> 0.20±0.02

● **Technical data vary with type of engine, therefore, they are subject to change without notice.**

## NOISE TESTING DATA

Measure according to ISO 8528-10, EN ISO 3744, European Directive 2000/14/EC and the noise was tested.

Max. sound pressure level at rated torque was max. 98dB( A).

Sound Power Level: 110dB(A)

## II. Torque of important bolts

Item	Specifications	Torque valve	
		N • m	kg • m
Tie-rod bolt	M8×1.25 (special)	14	1.4
Cylinder head bolt	M8×1.25	34	3.5
Flywheel nut	M20×1.5 (special)	113	11.5
Lock nut of rocker arm shaft	M6×0.75	10	1.0
Rocker arm stud	M8×1.25 (special)	24	2.4
Crankcase bolt	M8×1.25	24	2.4

### III. Fitting clearance and wear limit

S/N	Name	Normal value mm)	Wear limit (mm)
1	Bore	77.02	77.19
2	Outer dia. of piston skirt	76.97	76.62
3	Clearance between piston and cylinder	0.035~0.06	0.12
4	Dia. of piston pin hole	18.017	18.052
5	Outer dia. of piston pin	18	17.982
6	Clearance between piston pin and hole	0.006~0.035	0.08
7	Clearance between piston ring and cylinder	0.03~0.06	0.15
8	Width of piston ring	2.0	1.75
9	Width of scraper ring	2.4	2.3
10	Piston ring gap	0.2~0.4	1.0
11	Scraper ring gap	0.2~0.7	1.0
12	Inner dia. of tie-rod big end	40.041	40.09
13	Inner dia. of tie-rod small end	18.017	18.07
14	Oil clearance of tie-rod big end	0.040~0.066	0.12
15	Side clearance of tie-rod big end	0.1~0.7	1.0
16	Dia. of crankshaft	37.959	37.91
17	Clearance of intake valve	0.15±0.02	
18	Clearance of exhaust valve	0.20±0.02	
19	Dia. of intake stem	6.58	6.43
20	Dia. of exhaust stem	6.56	6.41
21	Inner dia. of valve guide	6.60	6.60
22	Clearance between intake valve and valve guide	0.02~0.047	0.10
23	Clearance between exhaust valve and valve guide	0.04~0.067	0.12

# ELECTRIC DIAGRAM

BL	Black	R	red
Y	yellow	W	white
GR	grey		

